









Apple-Cheese Bake

Ingredients

Makes 6-8 servings

- 6 cups **apples**, peeled and sliced  
- 1 Tablespoon **lemon juice** 
- 1/2 cup **sugar** 
- 1/2 cup **flour** 
- 1/4 teaspoon **cinnamon** 
- 1/4 cup **margarine** 
- 2/3 cup **cheese**, grated 

1 Preheat oven to 350° F.

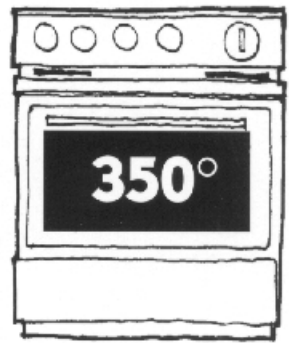

2 Place apple slices in a pan 8" X 8".

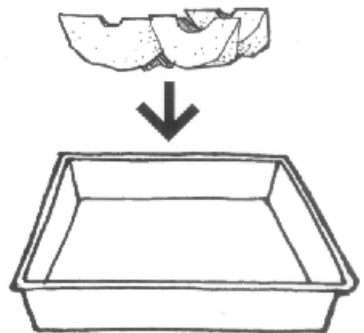

3 Sprinkle apples with lemon juice and half the sugar.

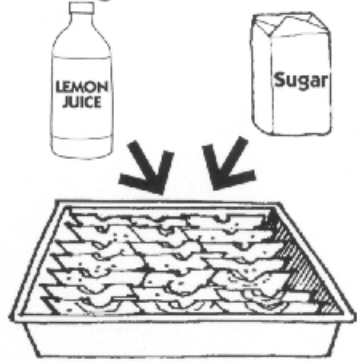

4 In a small bowl, mix the remaining sugar, flour, and cinnamon.

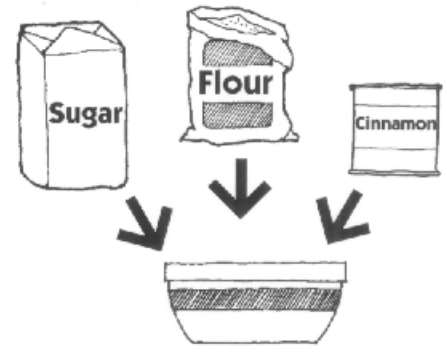

Apple-Cheese Bake

- 5** Add the margarine and mix well.

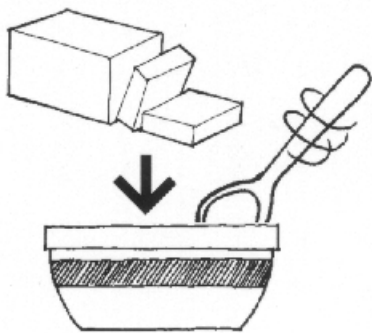

- 6** Add the cheese and mix well.

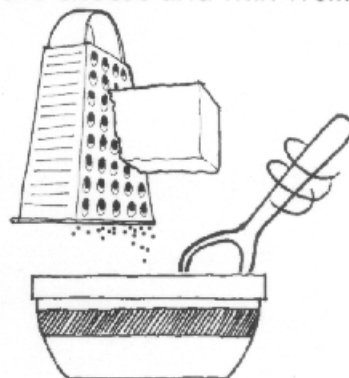

- 7** Sprinkle the flour mixture evenly over the apples.

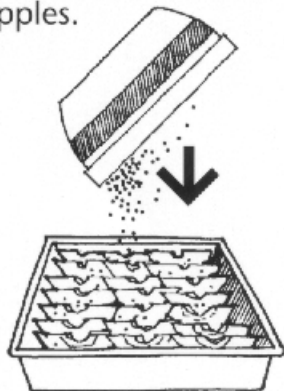

- 8** Bake for 45 minutes or until apples are soft.

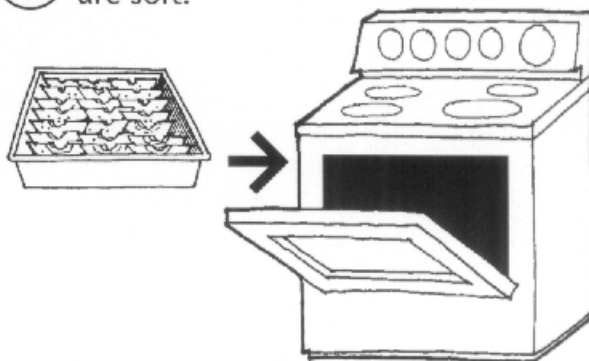

- 9** Refrigerate leftovers within 2 hours.

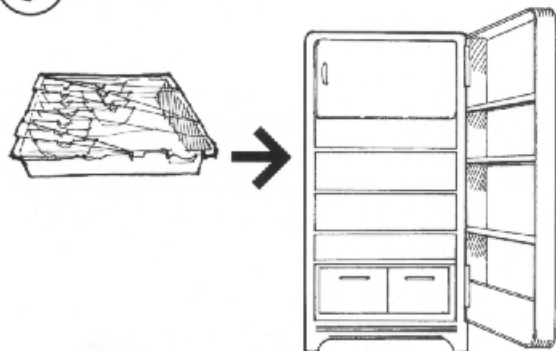

Apple Cheese Bake gives us:



Builds bones and teeth.

Fiber

Prevents constipation.



**OREGON STATE
UNIVERSITY**
EXTENSION SERVICE

Recipe Source: Oregon EFNEP Curriculum, Fruit Sheet 1.

9/99

Original format created by Janice Smiley, MPA, Extension Educator, Adult and 4-H Nutrition, Multnomah County.

Adapted and translated for use with Spanish speaking audiences by Lynn Myers Steele, MPH, Extension Educator, and Nutrition Assistants, Oregon Family Nutrition Program (OFNP), Hispanic Office, Multnomah County, 1994.

Funding for the Oregon Family Nutrition Program is made available through the Oregon Department of Human Resources from the USDA Food and Nutrition Service, Oregon State University (OSU) Extension Service cooperating. OSU Extension Service offers educational programs, activities, and material - without regard to race, color, religion, sex, sexual orientation, national origin, age, marital status, disability, and disabled veteran or Vietnam-era veteran status - as required by Title VI of the Civil Rights Act of 1964, Title IX of the Education Amendments of 1972, and Section 504 of the Rehabilitation Act of 1973. OSU Extension Service is an Equal Opportunity Employer.